

Direct current electronic drivers with DIP-SWITCH
Alimentatori elettronici in corrente continua con DIP-SWITCH

Made in Europe

SELV

constant
CURRENT



2.1

Multipower DIP-SWITCH drivers - Compact case
Alimentatori multipotenza con DIP-SWITCH - Formato compatto



SMART 70



SMART 70 BI



Rated Voltage
Tensione Nominale
220 ÷ 240 V

Frequency
Frequenza
50...60 Hz

AC Operation range
Tensione di utilizzo AC
198 ÷ 264 V

DC Operation range
Tensione di utilizzo DC
176 ÷ 264 V

Power
Potenza
15 ÷ 70W

Output current ripple
± 20%⁽¹⁾

Reference Norms
Norme di riferimento
EN 50172 (VDE 0108)
EN 55015
EN 61000-3-2
EN 61000-3-3
EN 61347-1
EN 61347-2-13
EN 61547
EN 62384
VDE 0710-T14

Max. pcs for CB B16A
(see page info17)
50 pcs

In rush current
5A 50µsec

Article Articolo	Code Codice	P out W	V out DC	I out DC	V out max.	ta °C	tc °C	λ max. Power Factor	η max. Efficiency ⁽¹⁾
SMART 70	127402	26	50...85	300 mA cost.	59	-25...+50	80	0,95	>90
SMART 70 BI	127400	30	43...85	350 mA cost.					
		32	38...85	400 mA cost.					
		35	33...85	450 mA cost.					
		40	30...85	500 mA cost.					
		45	25...85	550 mA cost.					
		50	25...85	600 mA cost.					
		55	25...85	650 mA cost.					
		60	25...86	700 mA cost.					
		64	25...85	750 mA cost.					
		70	25...88	800 mA cost.					
		70	25...82	850 mA cost.					
		70	25...77	900 mA cost.					
		70	25...74	950 mA cost.					
		70	25...70	1000 mA cost.					
		70	25...67	1050 mA cost.					

⁽¹⁾ Referred to V_{in} = 230 V, 100% load - Riferito a V_{in} = 230 V, carico 100%

Features

- Multipower driver supplied with dip-switch for the selection of the output current.
- IP20 independent driver, for indoor use (SMART).
- Class I protection against electric shock for direct or indirect contact (SMART).
- Driver for built-in use (SMART BI).
- It can be used for lighting equipment in protection class I (SMART BI).
- Active Power Factor Corrector.
- Current regulation ±5 % including temperature variations.
- Input and output terminal blocks on the same side (wire cross-section up to 1,5 mm² / AWG15).
- Clamping screws on primary and secondary circuits for cables with diameter: min. 3 mm - max. 8 mm (SMART).
- Driver can be secured with slot for screws.
- Protections:
 - against overheating and short circuits;
 - against mains voltage spikes;
 - against overloads.
- Thermal protection = C.5.a.

Caratteristiche

- Alimentatore multipotenza fornito di dip-switch per la selezione della corrente in uscita.
- Alimentatore indipendente IP20, per uso interno (SMART).
- Protetto in classe I contro le scosse elettriche per contatti diretti e indiretti (SMART).
- Alimentatore da incorporare (SMART BI).
- Utilizzabile per apparecchi di illuminazione in classe di protezione I (SMART BI).
- PFC attivo.
- Corrente regolata ±5 % incluse variazioni di temperatura.
- Morsetti di entrata e uscita sullo stesso lato (sezione cavo fino a 1,5 mm² / AWG15).
- Serracavo su primario e secondario per cavi di diametro: min. 3 mm - max. 8 mm (SMART).
- Fissaggio dell'alimentatore tramite asole per viti.
- Protezioni:
 - termica e cor tocricuito;
 - contro le extra-tensioni di rete;
 - contro isovraccarichi.
- Protezione termica = C.5.a.



Direct current electronic drivers with DIP-SWITCH
Alimentatori elettronici in corrente continua con DIP-SWITCH

Made in Europe



IP 20 **SCREW FIXING** Ø90 3,54" Weight - Peso gr. 250 / 9 oz.
Pcs - Pezzi 40

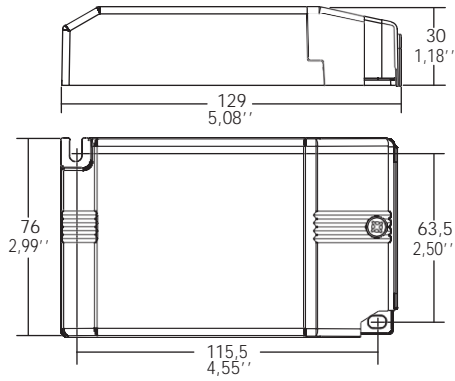

BUILT-IN **SCREW FIXING** Weight - Peso gr. 235 / 9 oz.
Pcs - Pezzi 40

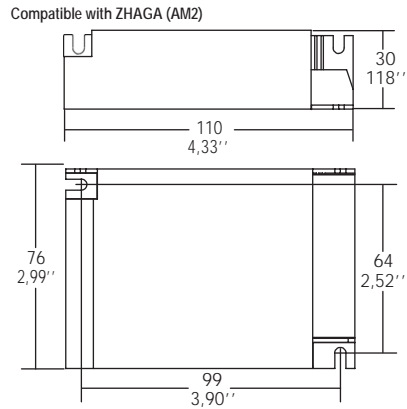

Wiring diagram - Schema di collegamento (Max. LED distance on page info8 - Massima distanza LED a pagina info8)

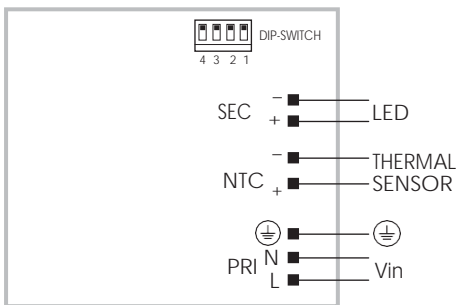

2.1

Multipower DIP-SWITCH drivers - Compact case
Alimentatori multipotenza con DIP-SWITCH - Formato compatto