

Direct current electronic drivers
Alimentatori elettronici in corrente continua

Made in Italy 

constant
VOLTAGE

**RIPPLE
FREE**



ERC   **SELV 60V**

Rated Voltage
Tensione Nominale
220 ÷ 240 V

Frequency
Frequenza
50-60 Hz

AC Operation range
Tensione di utilizzo AC
198 ÷ 264 V

DC Operation range
Tensione di utilizzo DC
(see page info15)
DC 176 ÷ 264 V

Power - Potenza
0 ÷ 12 W

iTHD
≥ 90% ⁽¹⁾

Output current ripple
≤ 3% ⁽¹⁾

Standards compliance
EN 50172 (VDE 0108)

EN 55015
EN 61000-3-2
EN 61000-3-3
EN 61347-1
EN 61347-2-13
EN 61547
EN 62384
VDE 0710-T14

Max. pcs for CB B16A
(see page info17)
50 pcs

In rush current
20A 170μsec

Article Articolo	Code Codice	P out W	V out DC	I out DC	ta °C	tc °C	λ max. Power Factor	η max. Efficiency ⁽¹⁾
DC 12W 12V UD	122740	12	12	1 A max.	-25...+50	75	0,58 C	> 80
DC 12W 24V UD	122742	12	24	0,5 A max.	-25...+50	75	0,58 C	> 80

⁽¹⁾ Referred to $V_m = 230$ V, 100% load - Riferito a $V_m = 230$ V, carico 100%

 **IP 20**   Weight - Peso gr. 80 / 2,82 oz.
Pcs - Pezzi 50

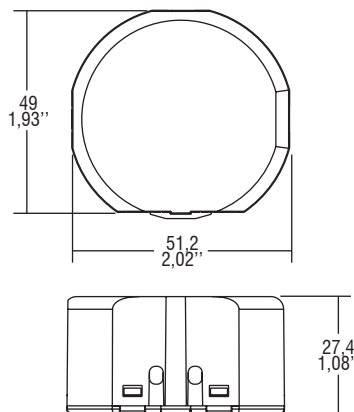

Features

- Driver suitable for flush-mounted box.
- IP20 driver, for indoor use.
- Protection against electric shock for direct or indirect contact, suitable for Class II installation.
- Cables on primary and secondary circuits for connection.
- If the input cable is damaged it can only be replaced by authorized personnel.
- Ultra compact size.
- Protections:
 - against overheating and short circuits;
 - against mains voltage spikes;
 - against overloads.
- Can be switched on and off on secondary circuit for power LED (for additional details page info15).

Wiring diagram - Schema di collegamento

(Max. LED distance at page info8 - Massima distanza LED a pagina info8)

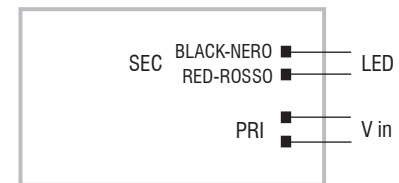

Caratteristiche

- Alimentatore adatto per l'inserimento nelle scatole di derivazione.
- Alimentatore IP20, per uso interno.
- Protetto contro le scosse elettriche per contatti diretti e indiretti, idoneo per installazione in Classe II.
- Fornito di cavi su primario e secondario per il collegamento.
- Se il cavo di rete è danneggiato deve essere sostituito da personale autorizzato.
- Dimensioni molto ridotte e compatte.
- Protezioni:
 - termica e cortocircuito;
 - contro le extra-tensioni di rete;
 - contro i sovraccarichi.
- Possibilità di accensione e spegnimento sul secondario per LED alimentati in corrente (per ulteriori dettagli pagina info15).

5.1.1

Constant voltage drivers - Compact case - Switchable
Alimentatori a tensione costante - Formato compatto - Non regolabili

7 YEARS WARRANTY
3% FAILURE RATE

10 YEARS WARRANTY
5% FAILURE RATE

PRODUCER'S LIABILITY
TCI

10 YEARS WARRANTY TO LEDING
ACCORDING TO THE CONTRACTOR'S CONDITIONS