

MINIJOLLY LC 20 - 1...10 V & PUSH

Direct current dimmable electronic drivers with DIP-SWITCH
Alimentatori elettronici regolabili in corrente continua con DIP-SWITCH

Made in Italy 

0/1...10 V **PUSH** **constant CURRENT**

RIPPLE FREE

AM DIMMING



DC MINI JOLLY



DC MINI JOLLY BI

3.1.1

Dimmable multipower DIP-SWITCH drivers - Compact case - 1-10V & PUSH
Alimentatori multipotenza regolabili con DIP-SWITCH - Formato compatto - 1-10V & PUSH

Rated Voltage
Tensione Nominale
110 ÷ 127 V ⁽²⁾
220 ÷ 240 V

Frequency
Frequenza
50...60 Hz

AC Operation range
Tensione di utilizzo AC
99 ÷ 264 V

DC Operation range
Tensione di utilizzo DC
(see page info15)
176 ÷ 280 V
(NO PUSH mode function)

Power
Potenza
1 ÷ 20 W

Output current ripple
≤ 3% ⁽¹⁾

Reference Norms
Norme di riferimento
CSA C22.2 no. 223 ⁽²⁾
EN 50172 (VDE 0108)
EN 55015
EN 61000-3-2
EN 61000-3-3
EN 61347-1
EN 61347-2-13
EN 61547
EN 62384
UL 1310 ⁽²⁾
VDE 0710-T14

Max. pcs for CB B16A
(see page info17)
50 pcs

In rush current
5A 50μsec

7 YEARS WARRANTY
3% FAILURE RATE

10 YEARS WARRANTY
5% FAILURE RATE

PRODUCER'S LIABILITY

10 YEARS WARRANTY TO THE END USER
ACCORDING TO THE EUROPEAN DIRECTIVE 2002/95/EC

Article Articollo	Code Codice	Dimming type	P out W	V out DC ⁽¹⁾	I out DC	V out max.	ta °C	tc °C	λ max. Power Factor	η max. Efficiency ⁽¹⁾
DC MINIJOLLY LC	151401	AM	Constant current output - Uscita in corrente costante			59	-25...+50	75	0,95 ⁽³⁾	> 89
DC MINIJOLLY LC BI	151401BI	AM	5,4 (5,4 ⁽²⁾)	20...54	100 mA cost.					
			6,4 (6,4 ⁽²⁾)	20...54	120 mA cost.					
			7,5 (7,5 ⁽²⁾)	10...53	140 mA cost.					
			8,5 (8,5 ⁽²⁾)	2...53	160 mA cost.					
			9,5 (9,5 ⁽²⁾)	2...53	180 mA cost.					
			10,6 (10,6 ⁽²⁾)	2...53	200 mA cost.					
			12 (12 ⁽²⁾)	2...53	220 mA cost.					
			12,5 (12,5 ⁽²⁾)	2...53	240 mA cost.					
			14 (14 ⁽²⁾)	2...53	260 mA cost.					
			15 (15 ⁽²⁾)	2...53	280 mA cost.					
			16 (16 ⁽²⁾)	2...52,5	300 mA cost.					
			17 (17 ⁽²⁾)	2...52	320 mA cost.					
			18 (18 ⁽²⁾)	2...52	340 mA cost.					
			19 (19 ⁽²⁾)	2...52	360 mA cost.					
			20 (20 ⁽²⁾)	2...52	380 mA cost.					

⁽¹⁾ Referred to V_m = 230 V, 100% load - Riferito a V_m = 230 V, carico 100%
⁽³⁾ Pout > 8W

Accessories not supplied - Accessori non a corredo	
Article - Articollo	Code - Codice
REG 1-10 V (12.3)	123999L
WIRELESS INTERFACES (W.)	-

Features

- Multipower driver supplied with dip-switch for the selection of the output current.
- IP20 independent driver, for indoor use (DC MINIJOLLY).
- Class II protection against electric shock for direct or indirect contact (DC MINIJOLLY).
- Driver for built-in use (DC MINIJOLLY BI).
- It can be used for lighting equipment in protection class I and II (DC MINIJOLLY BI).
- Active Power Factor Corrector.
- Current regulation ±5 % including temperature variations.
- Input and output terminal blocks on the same side (wire cross-section up to 1,5 mm² / AWG15).
- Clamping screws on primary and secondary circuits for cables with diameter: PRI 5-8 mm / SEC 3-5 mm (DC MINIJOLLY).
- Protections:
 - against overheating and short circuits;
 - against mains voltage spikes;
 - against overloads.
- Thermal protection = C.5.a.

Caratteristiche

- Alimentatore multipotenza fornito di dip-switch per la selezione della corrente in uscita.
- Alimentatore indipendente IP20, per uso interno (DC MINIJOLLY).
- Protetto in classe II contro le scosse elettriche per contatti diretti e indiretti (DC MINIJOLLY).
- Alimentatore da incorporare (DC MINIJOLLY BI).
- Utilizzabile per apparecchi di illuminazione in classe di protezione I e II (DC MINIJOLLY BI).
- PFC attivo.
- Corrente regolata ±5 % incluse variazioni di temperatura.
- Morsetti di entrata e uscita sullo stesso lato (sezione cavo fino a 1,5 mm² / AWG15).
- Serracavo su primario e secondario per cavi di diametro: PRI 5-8 mm / SEC 3-5 mm (DC MINIJOLLY).
- Protezioni:
 - termica e cortocircuito;
 - contro le extra-tensioni di rete;
 - contro i sovraccarichi.
- Protezione termica = C.5.a.

MINIJOLLY LC 20 - 1...10 V & PUSH

Direct current dimmable electronic drivers with DIP-SWITCH
Alimentatori elettronici regolabili in corrente continua con DIP-SWITCH

Made in Italy

IP 20 **SCREW FIXING** **Ø55 2.17"** Weight - Peso gr. 108 / 3,50 oz.
Pcs - Pezzi 50

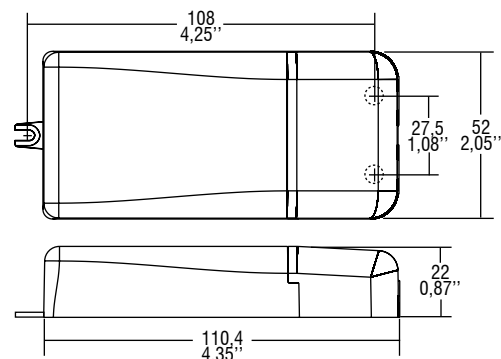

BUILT-IN **SCREW FIXING** Weight - Peso gr. 100 / 3,50 oz.
Pcs - Pezzi 50

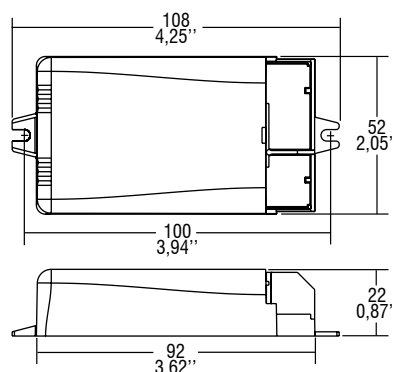

Wiring diagram - Schema di collegamento (Max. LED distance on page info8 - Massima distanza LED a pagina info8)

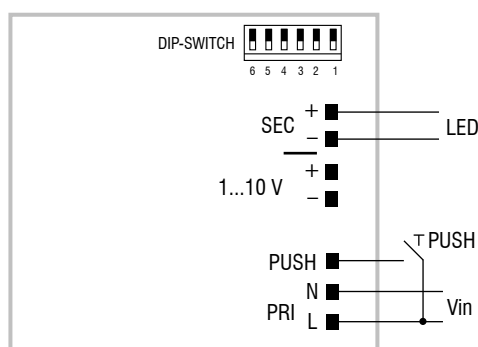

PUSH diagram - Collegamento PUSH

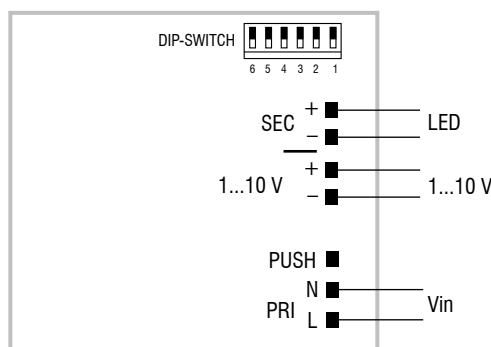

1...10 V diagram - Collegamento 1...10 V

Operation Mode

- Light regulation 0/1 - 100 % by means of PUSH function, 0/1...10 V interface ($I=0,35$ mA) or 100 Kohm potentiometer.
- **Full AM DIMMING: 1-100%.**
- Light regulation 0/1 - 100 % by means of PUSH function (L mains voltage: 170 Kohm):
 - a short push to turn on and off;
 - a longer push to increase or decrease light intensity;
 - regulation automatically stops at minimum and maximum values;
 - for another on, regulation or off command, release the push button and give the desired command again;
 - **dimming level memory at mains restore.**
- Maximum length of the cable, from push button to last driver, must be max. 15 m / 49 ft. In case of applications where the cable is longer than 15 m / 49 ft, keep this separate from the 110 - 240 Volt mains cable.
- ATTENTION: only use normally open push buttons with no incorporated warning light.
- Specific dimming terminal connection with a 0/1...10 Vdc electronic potentiometer (0/1...10 V local dimming, double insulation required for external connection).

For additional details for regulations see pages info12-14.

Modalità di funzionamento

- Regolazione della luminosità 0/1 - 100 % mediante funzione PUSH, interfaccia 0/1...10 V ($I=0,35$ mA) o potenziometro da 100 Kohm.
 - **Regolazione solo AM: 1-100%.**
 - Regolazione della luminosità 0/1 - 100 % mediante la funzione PUSH (tensione di rete L; 170 Kohm):
 - una pressione breve per accendere e spegnere;
 - una pressione prolungata per aumentare o diminuire l'intensità luminosa;
 - la regolazione si ferma automaticamente ai valori minimi e massimi;
 - per un nuovo comando accensione, regolazione o spegnimento, rilasciare il pulsante e dare nuovamente il comando desiderato;
 - **ripristino del livello di dimming al ritorno alimentazione.**
 - La lunghezza massima del cavo, dal pulsante all'ultimo trasformatore, deve essere max. 15 m / 49 ft. In caso di applicazioni dove il cavo superi i 15 m / 49 ft, tenere lo stesso separato dal cavo di rete 110 - 240 Volt.
 - ATTENZIONE: usare solo pulsanti di tipo normalmente aperto privi di spia luminosa incorporata.
 - Provisto di morsetto specifico per la regolazione collegando un potenziometro elettronico 0/1...10 Vdc (dimmerazione locale 0/1...10 V, per connessioni esterne all'apparecchio garantire il doppio isolamento).
- Per ulteriori dettagli sulle regolazioni vedi pagine info12-14.

3.1.1

Dimmable multipower DIP-SWITCH drivers - Compact case - 1-10V & PUSH
Alimentatori multipotenza regolabili con DIP-SWITCH - Formato compatto - 1-10V & PUSH