

Direct current dimmable (TRAILING EDGE-LEADING EDGE) electronic drivers with DIP-SWITCH
Alimentatori elettronici regolabili (IGBT-TRIAC) in corrente continua con DIP-SWITCH

Made in Italy 

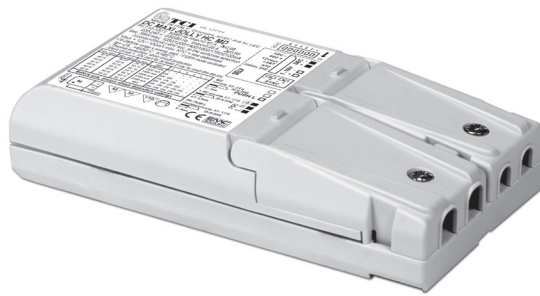

IS 15885
(Part 2 / Sec 13)
S (4)
R-41049751



MAXI JOLLY HC MD



MAXI JOLLY HC MD BI

3.1.3

Dimmable multipower drivers - Compact case - PHASE CUT
Alimentatori multipotenza regolabili - Formato compatto - TAGLIO DI FASE



Rated Voltage
Tensione Nominale
220 ÷ 240 V

Frequency
Frequenza
50-60 Hz

AC Operation range
Tensione di utilizzo AC
198 ÷ 264 V

Power - Potenza
1 ÷ 50 W

iTHD
≤ 15% (1)

Stand by power
≤ 0,5 W

Output current ripple
≤ 3% (1)

Standards compliance
EN 50172 (VDE 0108)
EN 55015
EN 60598-1
EN 61000-3-2
EN 61000-3-3
EN 61347-1
EN 61347-2-13
EN 61547
EN 62384
VDE 0710-T14

Max. pcs for CB B16A
(see page info17)
30 pcs

In rush current
10A 200µsec

Article Articolo	Code Codice	P out W	V out DC	I out DC	U out V	ta °C	tc °C	λ max. Power Factor	η max. Efficiency ⁽¹⁾
DC MAXI JOLLY HC MD (3)(6)	127550	45	2...43	1,05 A cost.	55	-25... +45 ^{(3)/50⁽⁶⁾}	80 ⁽³⁾ 85 ⁽⁶⁾	0,95 ⁽²⁾	> 88
DC MAXI JOLLY HC MD BI (5)	127552	50	2...42	1,2 A cost.					
		50	2...36	1,4 A cost.					
		50	2...31	1,6 A cost.					
		50	2...28	1,75 A cost.					
		50	2...23	2,1 A cost.					

(1) Referred to $V_m = 230$ V, 100% load - Riferito a $V_m = 230$ V, carico 100%

(2) Pout > 25 W

(4) 127550BIS:
order code for BIS marked product
codice di ordine per il prodotto marchiato BIS

Accessories not supplied - Accessori non a corredo	
Article - Articolo	Code - Codice
ETDU29 (12.2)	180426
ETD2E9 (12.2)	180427

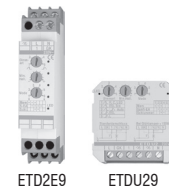

Features

- **Double terminal blocks to loop other driver (max. 5 A).**(3)
- Multipower driver supplied with dip-switch for the selection of the output current.
- IP20 independent driver, for indoor use.
- Class I protection against electric shock for direct or indirect contact.
- It can be used for lighting equipment in protection class I.
- Active Power Factor Corrector.
- Current regulation ±5 % including temperature variations.
- Input and output terminal blocks on the same side (wire cross-section up to 1,5 - 2,5 mm² / AWG15 - AWG13).
- Clamping screws on primary and secondary circuits for cables with diameter: min. 3 mm - max. 8 mm.
- Protections:
 - against overheating and short circuits;
 - against mains voltage spikes;
 - against overloads.
- Thermal protection = C.5.a.





Caratteristiche

- **Doppia morsettiera lato rete per rimando ad altro alimentatore (max. 5 A).**(3)
- Alimentatore multipotenza fornito di dip-switch per la selezione della corrente in uscita.
- Alimentatore indipendente IP20, per uso interno.
- Protetto in classe I contro le scosse elettriche per contatti diretti e indiretti.
- Utilizzabile per apparecchi di illuminazione in classe di protezione I.
- PFC attivo.
- Corrente regolata ±5 % incluse variazioni di temperatura.
- Morsetti di entrata e uscita sullo stesso lato (sezione cavo fino a 1,5 - 2,5 mm² / AWG15 - AWG13).
- Serracavo su primario e secondario per cavi di diametro: min. 3 mm - max. 8 mm.
- Protezioni:
 - termica e cortocircuito;
 - contro le extra-tensioni di rete;
 - contro i sovraccarichi.
- Protezione termica = C.5.a.



Direct current dimmable (TRAILING EDGE-LEADING EDGE) electronic drivers with DIP-SWITCH
Alimentatori elettronici regolabili (IGBT-TRIAC) in corrente continua con DIP-SWITCH

Made in Italy 

 **IP 20**  **SCREW FIXING**  Ø88 3,46"  Weight - Peso gr. 240 / 8,5 oz.
Pcs - Pezzi 40

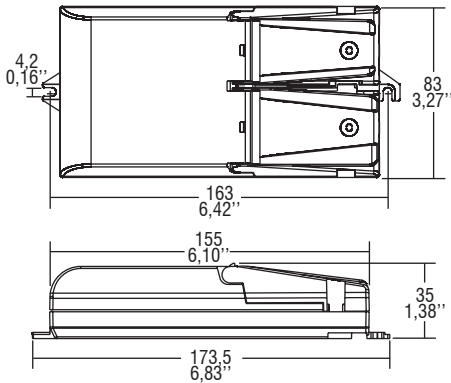

BUILT-IN  **SCREW FIXING** Weight - Peso gr. 235 / 8,3 oz.
Pcs - Pezzi 40
Compatible with ZHAGA (AM2)

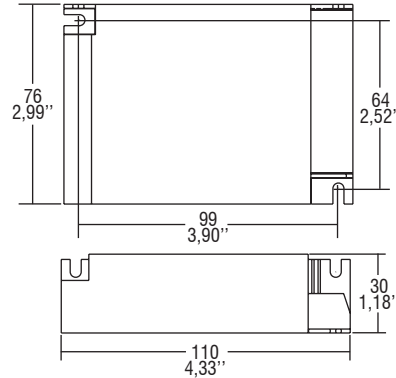

Wiring diagram - Schema di collegamento (Max. LED distance on page info8 - Massima distanza LED a pagina info8)

DC MAXI JOLLY HC MD

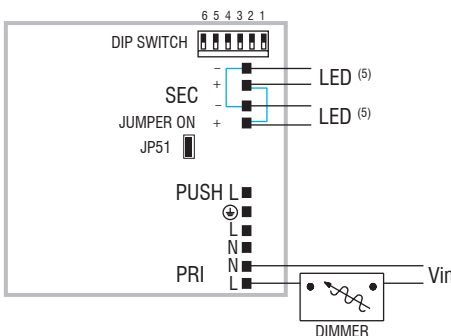

PHASE-OUT dimming - To avoid flickering, keep the slaves at 100% dimming level.
Dimmerazione TAGLIO DI FASE - Per evitare flicker, i singoli slaves devono essere lasciati con dimming 100%.
[Internally wired - Collegato all'interno.](#)

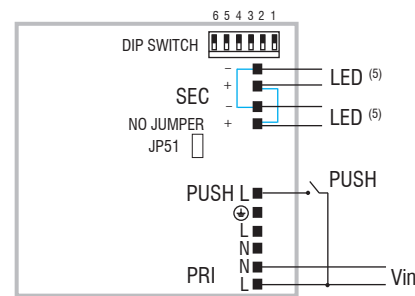

PUSH diagram - Collegamento PUSH
[Internally wired - Collegato all'interno.](#)

DC MAXI JOLLY HC MD BI

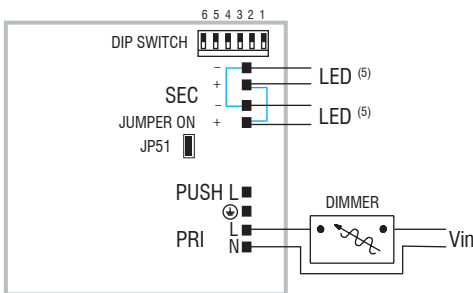

PHASE-CUT dimming - To avoid flickering, keep the slaves at 100% dimming level.
Dimmerazione TAGLIO DI FASE - Per evitare flicker, i singoli slaves devono essere lasciati con dimming 100%.
[Internally wired - Collegato all'interno.](#)

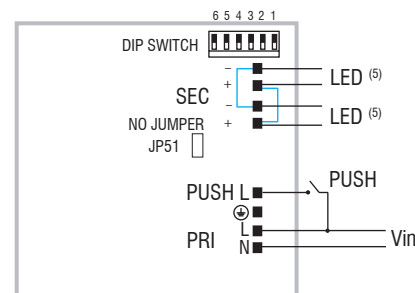

PUSH diagram - Collegamento PUSH
[Internally wired - Collegato all'interno.](#)

Operation Mode

- Regulating driver with "phase cut-off" dimmer IGBT, TRIAC and PUSH.
 - Light regulation 0/0,5 - 100 % by means of PUSH function (mains voltage):
 - a short push to turn on and off;
 - a longer push to increase or decrease light intensity;
 - regulation automatically stops at minimum and maximum values;
 - for another on, regulation or off command, release the push button and give the desired command again;
 - dimming level memory at mains restore.
 - Maximum length of the cable, from push button to last transformer, must be max. 15 m / 49 ft. In case of applications where the cable is longer than 15 m / 49 ft, keep this separate from the 220 - 240 Volt mains cable.
 - ATTENTION: only use normally open push buttons with no incorporated warning light.
 - ⁽⁵⁾ For constant current LED load only 1 output should be connected. The 2 LED outputs can be connected only for constant voltage LED loads.
- For additional details for regulations see pages info12-14.

Modalità di funzionamento

- Alimentatore regolabile con dimmer a "taglio di fase" IGBT, TRIAC e PUSH.
 - Regolazione della luminosità 0/0,5 - 100 % mediante la funzione PUSH (tensione di rete):
 - una pressione breve per accendere e spegnere;
 - una pressione prolungata per aumentare o diminuire l'intensità luminosa;
 - la regolazione si ferma automaticamente ai valori minimi e massimi;
 - per un nuovo comando accensione, regolazione o spegnimento, rilasciare il pulsante e dare nuovamente il comando desiderato;
 - ripristino del livello di dimming al ritorno alimentazione.
 - La lunghezza massima del cavo, dal pulsante all'ultimo trasformatore, deve essere max. 15 m / 49 ft. In caso di applicazioni dove il cavo superi i 15 m / 49 ft, tenere lo stesso separato dal cavo di rete 220 - 240 V.
 - ATTENZIONE: usare solo pulsanti di tipo normalmente aperto privi di spia luminosa incorporata.
 - ⁽⁵⁾ Per LED a corrente costante solo 1 uscita dovrebbe essere utilizzata. Le 2 uscite possono essere utilizzate solo per LED a tensione costante.
- Per ulteriori dettagli sulle regolazioni vedi pagine info12-14.

3.1.3

Dimmable multipower drivers - Compact case - PHASE CUT
Alimentatori multipotenza regolabili - Formato compatto - TAGLIO DI FASE